

DOES:

- 1) USB Power and com to module for bench use
- 2) JTAG access
- 3) Backwards capability with older boards and CHIMU 1
- 4) Acts as a pass thru board to allow debug in assembly

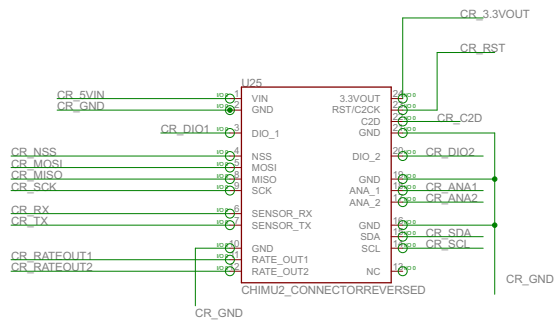
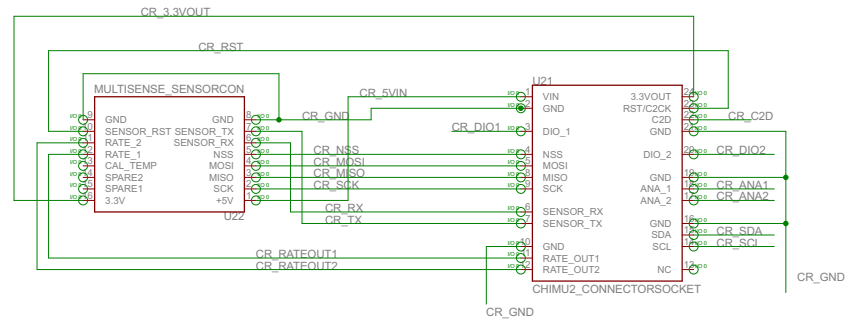

4 = 3.3V, 3 = RST/C2CK, 2=C2D, 1 = GND

X7-4 CR 3.3VOUT
 X7-3 CR RST
 X7-2 CR C2D
 X7-1 CR_GND
 53047-04

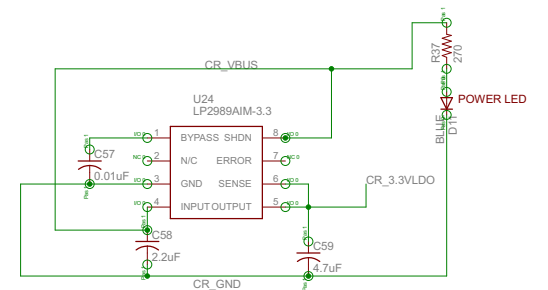
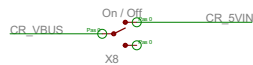

NOTE 2.2uF X7R 0805 on input, 4.7uF X7R 0805 on output
 NOTE .01uF X7R 0805 on Bypass

ISSUE	Ryan Mechatronics	Aliso Viejo, CA U.S.A.	THIS DRAWING CONTAINS PROPRIETARY INFORMATION AND SHOULD NOT BE USED WITHOUT WRITTEN PERMISSION.	© 2007
DRAWN	TITLE USB Node			REV A
CHECKED	DATE 11/10/2009 10:06:07 PM			DRG N°
DATE	FILE: USBNode			PAGE: 1/1